

Description

The Si4730/31 is the industry's first fully integrated, 100% CMOS AM/FM radio receiver IC. The Si4730/31-D60 AM/FM radio delivers excellent performance and is simple to design-in. Available in a small 3 x 3 mm QFN package, the Si4730/31 offers unmatched integration and PCB space savings with a minimal number of external components and no factory tuned components.

Leveraging Silicon Laboratories' proven and patented digital receiver architecture, the Si4730/31 delivers superior RF performance and interference rejection in both AM and FM bands. The high integration and complete system production test simplifies design-in, increases system quality, and improves manufacturability.

The Si4730/31 solution includes advanced seek algorithms, multipath detection and mitigation, adjustable soft mute, FM hi-cut control, smart tune, and FM stereo processing. In addition, the Si4730/31 provides an auxiliary input to support a full digital system architecture.

The Si4730/31 utilizes digital processing to achieve high fidelity, optimal performance, and design flexibility. The chip provides excellent pilot rejection, selectivity, and unmatched audio performance, and offers both the manufacturer and the end-user extensive programmability and flexibility in listening experience.

The Si4731-D60 incorporates an advanced digital processor for the European Radio Data System (RDS) and the North American Radio Broadcast Data System (RBDS) including all required symbol decoding, block synchronization, error detection, and error correction functions. Using this feature, the Si4731 enables broadcast data such as station identification and song name to be displayed to the end user.

Features

- Worldwide FM band support (64–108 MHz)
- Worldwide AM band support (520–1710 kHz)
- AM/FM digital tuning
- EN55020 compliant
- FM multipath detection and mitigation
- FM hi-cut control
- Advanced stereo blend
- AUXIN stereo ADC
- No manual alignment required
- Seven selectable AM channel filters
- Advanced AM/FM seek tuning
- Programmable AVC max gain
- Frequency synthesizer with integrated VCO
- Automatic frequency control (AFC)
- Programmable de-emphasis
- Digital FM stereo decoder
- Integrated LDO regulator
- Wide range of ferrite and air loop antennas supported
- Advanced FM RDS/RBDS processor
- QFN and SSOP Pb-free/RoHS compliant package

Applications

- Audio video receivers
- Mini/micro systems
- Home theater systems
- Docking stations
- Blu-ray / DVD players
- Table / clock radios
- Boomboxes

Pin Assignments

Si473x (QFN)

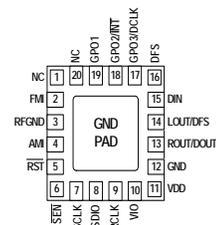

Si473x (SSOP)

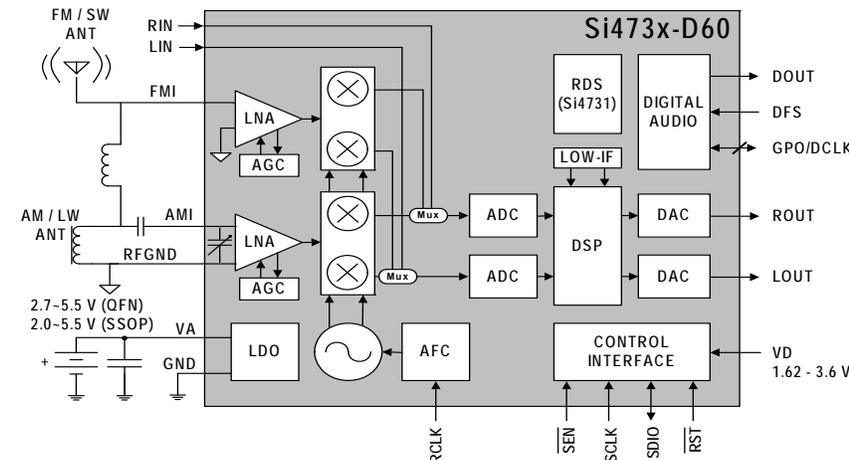
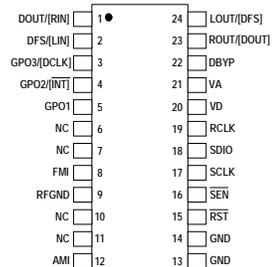

New Si4730/31-D60 Features

FM Multipath Detection and Mitigation

Provides the ability to detect a multipath situation and maintain audio SNR fidelity. Multipath mitigation is important in RF environments with high signal scatterings such as cities with tall buildings.

FM Hi-Cut Control

Hi-cut control is employed to increase the audio quality during low SNR and/or multipath situations. Hi-cut on the Si4730/31-D60 improves the sound quality by seamlessly selecting 1 of 7 different audio filters to optimize SNR versus audio frequency range. The end result is lower noise on weak stations and stations suffering from multipath.

Advanced Stereo Blend

The Si4730/31-D60 uses RSSI, SNR, and multipath to determine the best blend setting, providing an enhanced user listening experience. Utilizing these three metrics, stereo blend is optimized to allow for full stereo in high fidelity situations and a blended or full mono in sub-optimal conditions. Traditional stereo blend only uses the receive signal strength indicator (RSSI) to blend from stereo to mono.

Auxiliary Input

The optional analog auxiliary input (line-in) eliminates the need for an ADC when using a digital system architecture. The left and right auxiliary inputs get digitized on-chip. Audio output formats include I2S, Left-justified, and Right-justified.

Advanced RDS Processor

The Si4731-D60 implements an advanced, high-performance RDS processor for demodulation, symbol decoding, block synchronization, error detection, and error correction. The advance RDS decoder provides improved RDS sensitivity, excellent RDS persistence, faster lock, and lower decoder error rates resulting in acquiring RDS information faster and greater data reliability in low SNR environments.

Smart Tune

The Si4730/31-D60 automatically selects the IF injection side to optimize the SNR. This improves the desired station reception in areas that have large near-in blockers.

Selected Electrical Specifications

Parameter	Symbol	Test Condition	Min	Typ	Max	Unit
FM Input Frequency	f_{RF}		64	—	108	MHz
AM Input Frequency	f_{RF}		520	—	1710	kHz
FM Sensitivity with 50 Ω network		(S+N)/N = 26 dB	—	1.1	—	μ V EMF
RDS Sensitivity			—	8	—	μ V EMF
AM Sensitivity		(S+N)/N = 26 dB	—	25	—	μ V EMF
Input IP3		$ f_2 - f_1 > 1 \text{ MHz}; f_0 = 2 \times f_1 - f_2$	—	105	—	dB μ V EMF
FM Adjacent Channel Selectivity		$\pm 200 \text{ kHz}$	—	50	—	dB
FM Alternate Channel Selectivity		$\pm 400 \text{ kHz}$	—	70	—	dB
FM Audio Stereo Separation			34	42	—	dB
FM Audio S/N			—	63	—	dB
AM Audio S/N			—	56	—	dB
AM and FM Audio THD			—	0.1	—	%